

ASSEMBLED MODEL NO.	PLUNGER PART NO.	CAM STYLE	ASSEMBLED ORIENTATION
LI-4163-10-S-0	81400215	STR	0
LI-4163-10-S-60			60
LI-4163-10-S-120			120
LI-4163-10-S-30			30
LI-4163-10-S-90			90
LI-4163-10-S-150	81400225	LH	0
LI-4163-10-L-60			60
LI-4163-10-L-120			120
LI-4163-10-L-30			30
LI-4163-10-L-90			90
LI-4163-10-L-150	81400235	RH	0
LI-4163-10-R-60			60
LI-4163-10-R-120			120
LI-4163-10-R-30			30
LI-4163-10-R-90			90
LI-4163-10-R-150	81400265		150

NO	QTY	PART NO	DESCRIPTION	SEAL KIT	CLEVIS PIN KIT
1	3	23050024	RING, RTNG, EXT, 0.625		X
2	2	23340005	STOCK, CORD, .63 X 1.31, 50, NBR		X
3	3	23350087	SPRING, COMPRESSION	X	
4	3	23650011	BALL, TUNGSTEN-CARBIDE, 8mm	X	
5	4	39051080	O-RING, (10mm X 1)	X	
6	1	39051085	O-RING, (63mm X 2)	X	
7	2	39051088	O-RING, (8mm X 3)	X	
8	1	39053046	SEAL, WIPER, SNAP IN, WED, 36, 94A, AU	X	
9	1	39056006	SEAL, STEP, ROD, 36	X	
10	1	39056025	SEAL, CAP, PISTON, 63, 90A, AU GRPHT FLD	X	
11	2	43068006	PLUG, PORT, HOLLOW HEX, G1/4		
12	1	81400155	CAP, LC/SC, 7MPa, 63B		
13	4	81400201	PLUG, MANIFOLD, 7MPa, M10		
14	3	81400204	PIN, STOP, BALL, METRIC, 8mm BALL	X	
15	1	81400275	PIN, ROCKER, SC, 7MPa, 63B		X
N/A	N/A	L6014630	KIT, SEAL, SC, 7MPa, 63B	NOTED	N/A
N/A	N/A	L6214630	KIT, CLEVIS PIN, SC, 7MPa, 63B	N/A	NOTED

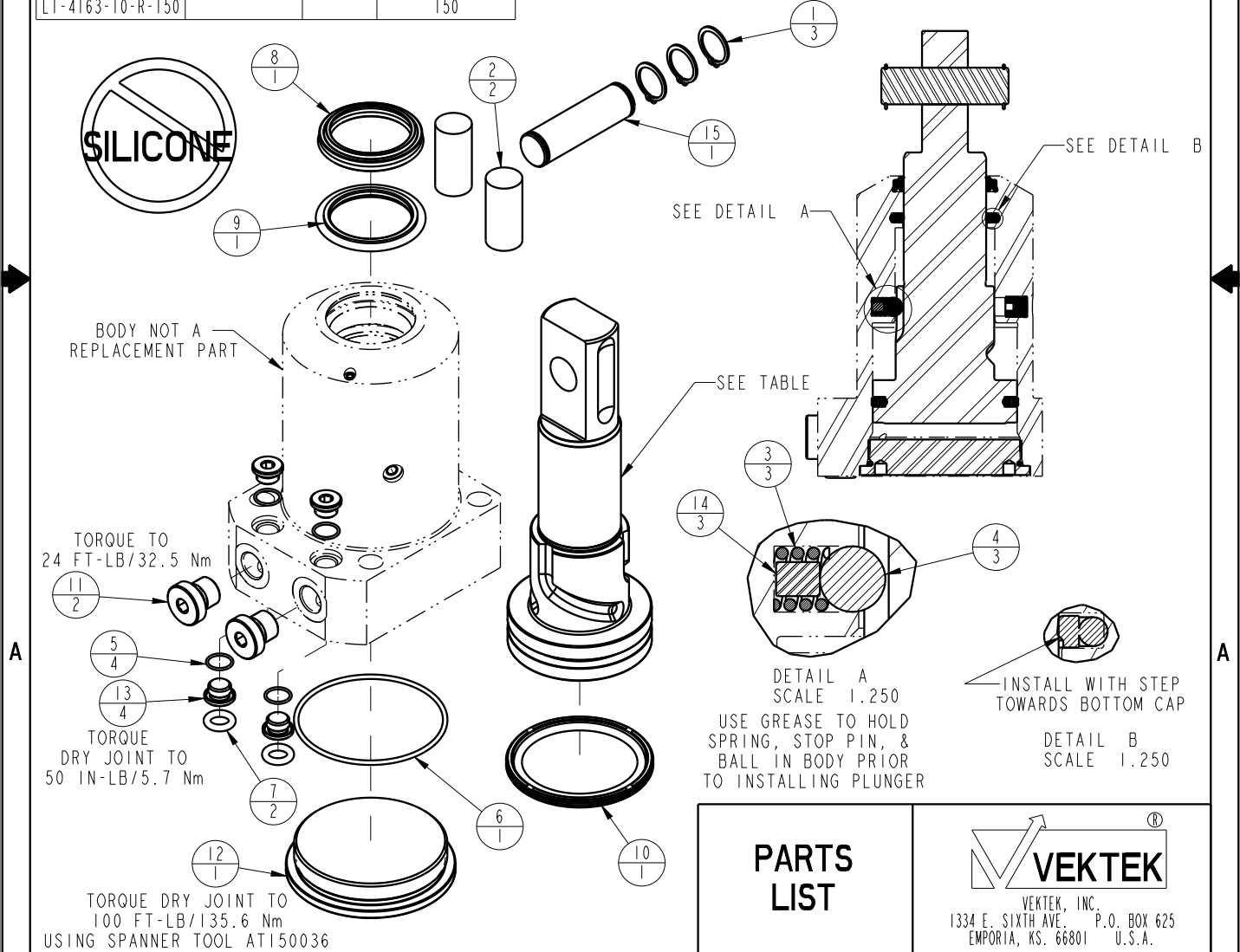

PARTS LIST		VEKTEK®	
ASSEMBLIES AFFECTED SEE ASSEMBLY MODEL NO. TABLE ABOVE		VEKTEK, INC. 1334 E. SIXTH AVE. P.O. BOX 625 EMPORIA, KS. 66801 U.S.A.	
SIZE A	LPL1434	REV B	

B	3273	RELEASE	JDW	08/15/18
REV	IN ACCORDANCE WITH ECN	EFFECTIVE DATE	REVISED BY	DATE
DRW BY: MAJ	DRAWING STATUS: Released			
DATE: 4-16-15	PRODUCTION APPROVED FOR RELEASED STATUS ONLY			